

MEK DEWAXING

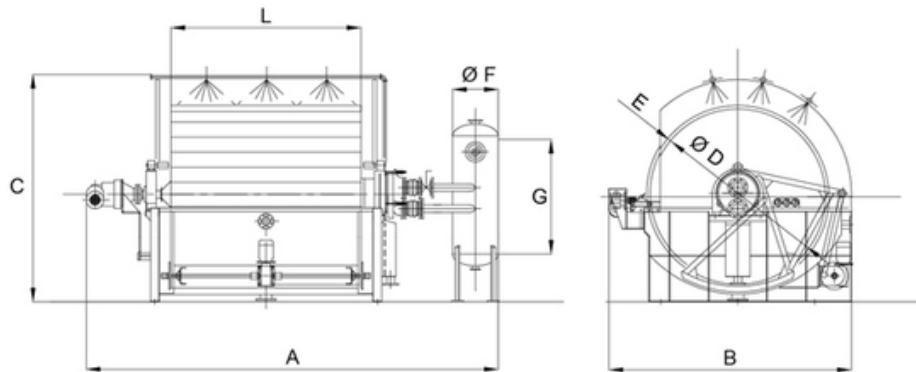

FILTER AREA m ²	DRUM (Ø) DxL	A	B	C
38	3.352 x 3.650	573	420	412
45	3.352 x 4.250	633	420	412
48	3.352 x 4.600	668	420	412
51	3.352 x 4.900	698	420	412
58	3.352 x 5.490	757	420	412
65	3.352 x 6.175	825	420	412
70	3.352 x 6.705	878	420	412
77	3.352 x 7.320	938	420	412
84	3.352 x 7.945	1000	420	412
90	3.352 x 8.535	1060	420	412
96	3.352 x 9.145	1120	420	412
102	3.352 x 9.750	1185	420	412
106	3.352 x 10.065	1215	420	412
110	3.352 x 10.500	1260	420	412
112	3.352 x 10.650	1280	420	412
115	3.352 x 11.000	1315	420	412